

Narrow Belt Roller Conveyor

Product Information



Keeping Europe Moving



The UK's Largest Roller and Conveyor Manufacturer



visit us at www.conveyor-units.co.uk

Features

- Offers maximum system throughput rates
- Available in transport or accumulation variants
- Efficient self steering belt support mechanisms
- Flat belt drive
- Range of drive packs

Benefits

- Increased capacity of your conveyor system
- Ability to transport or accumulate with the option to upgrade from one to the other
- Convey up to 30m from one drive
- Silent and low maintenance
- Optimum drive size selection for lower energy costs



Description

The UNI-XU[®] Narrow Belt conveyor can be used for either transportation or zero pressure accumulation of cartons and totes at speeds of up to 120m/min. Using a narrow belt and live roller drive principle, it achieves exceptionally high throughput rates with almost silent operation.

Both the transport and accumulation variants are constructed from the same components and benefit from the same self tracking belt support mechanism, which enable long conveyor lengths from just one drive. The accumulation conveyor is factory fitted with integral photocells and accumulation logic, meaning the controls interface is extremely simple requiring only a release signal to the front of the conveyor. The transport conveyor does not need these components but can be easily upgraded at any time to achieve accumulation.

Designed with energy efficiency in mind, there is a range of drive packs available which enable the right sized motor to be selected for the application, to avoid any unnecessary power consumption. In addition, during accumulation the load is actually removed from the drive meaning power consumption is further reduced when the product is stopped.

The UNI-XU[®] Narrow Belt conveyor provides exceptional performance, high reliability and industry leading throughput rates. Designed to reduce maintenance and operational costs, the UNI-XU[®] Narrow Belt conveyor is easy to maintain, requires minimal tools and sets new industry standards.

Conveyor Speeds

10, 20, 30, 40, 48, 60, 72 and 100m/min

Roller Pitch

75, 100, 125 and 150mm

Roller Diameter

50mm

Widths Available

412mm to 1012mm in 50mm increments

Electrical Supply

Motor should be connected to 400V 3ph 50Hz supply

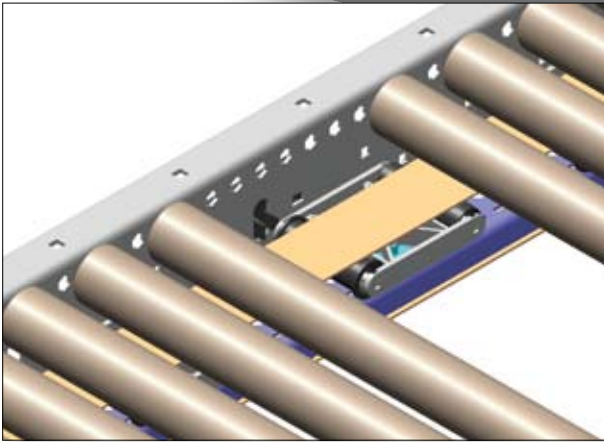

Self Tracking Belt Support Mechanism

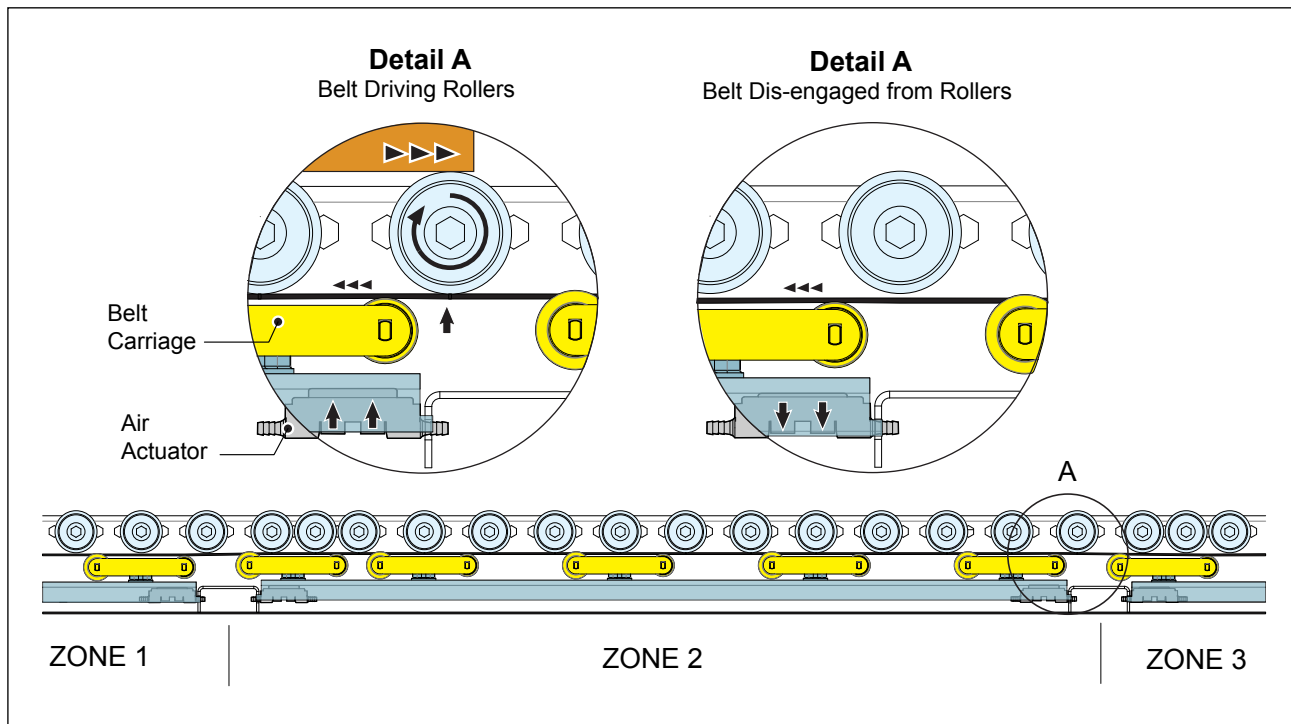

Other products by Conveyor Units include:-

Lineshaft Conveyors
Pallet Conveyors
Belt Conveyors
High Speed Switch Sorters
Zero Line Pressure Conveyors
Gravity Conveyors
Stainless Steel Conveyors
Flexible Conveyors
Conveyor Rollers & Spares



Conveyor Units Ltd

Sandy Lane, Titton, Stourport-on-Severn, Worcestershire, DY13 9PT.

Tel: 0044 (0)1299 877541 Fax: 0044 (0)1299 877921

email: sales@conveyor-units.co.uk | www.conveyor-units.co.uk | www.conveyorspares.co.uk