

Zero Line Pressure Conveyor

Product Information



Keeping Europe Moving



The UK's Largest Roller and Conveyor Manufacturer



visit us at www.conveyor-units.co.uk

Features

- Integral photocells without the need for external controls
- Modular conveyor design
- Robust low voltage 24V DC brushless Motorised Drive Rollers (MDR), or external Servo Motors with long motor life
- Zero contact product accumulation with singulation or train release of loads

Benefits

- Zone management without the need for expensive PLC programming
- Run-on-demand: Low energy consumption (motors stop when no load is present) and low noise
- Eliminate product damage from pressured accumulation alternatives
- Minimal maintenance (reduced components compared with traditional systems)

Description

Conveyor Units 24V DC Zero Line Pressure Roller Conveyor offers product accumulation with integral photocells, without the need for external controls. This type of conveyor with decentralised drives is highly modular, creating the possibility to add/remove zones from conveyor schemes with ease.

UNI-XU[®] MDR Conveyor

Option 1: Plug and Play cabling for ZLP with minimal control interfacing

The simplest conveyor of its kind, driven by 24V DC motorised drive rollers with integral DC circuitry. Supplied completely wired with innovative cabling which contains all the interconnections necessary between the photocells, motorised drive rollers and power feeds, eliminating the need to connect and terminate lots of wires on site.

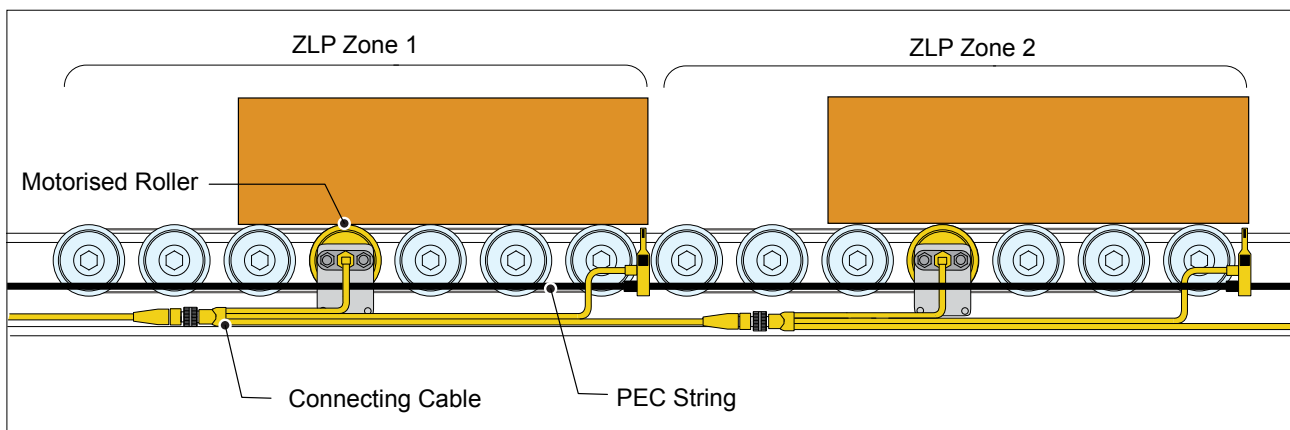

UNI-XU[®] MDR Conveyor

Option 2: Intelligent control for ZLP with PLC interfacing

This solution offers a greater degree of upper level control interface to a plc / master control with several additional control features:-

- Motorised drive roller speed
- Load jam detection signal
- Sensor status output to master control
- Self correcting load spacing
- Error signal to master control in case of overload activation

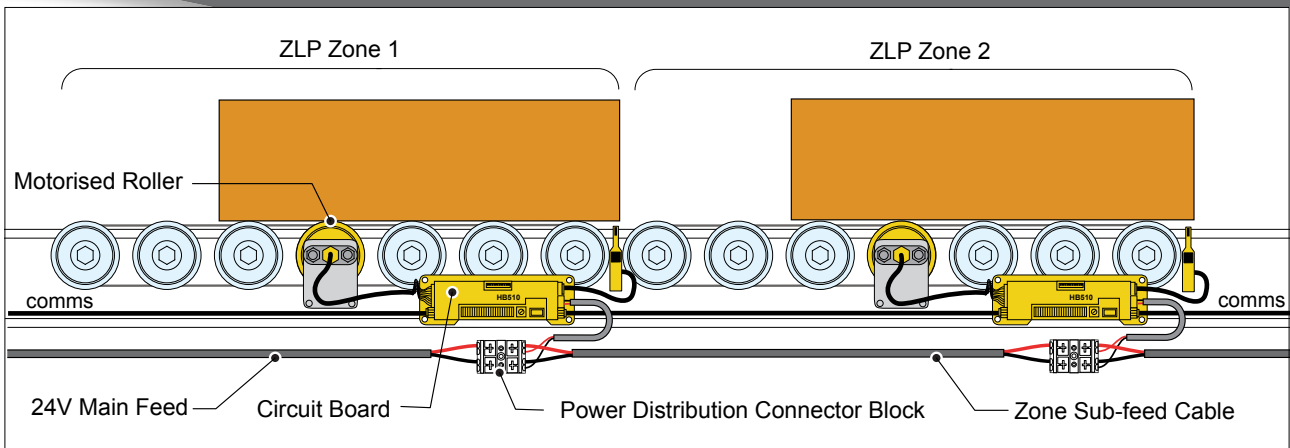

UNI-XU[®] UNIDrive Conveyor

This ZLP conveyor uses a compact gearless 24V DC brushless servo motor and offers further benefits beyond that of the UNI-XU[®] MDR Conveyor, making it suitable for higher specification applications due to the benefits of:-

- Higher torque and shock loading
- Almost silent operation
- Higher speed possibility as there are no fixed gear ratios
- Availability – one drive unit for all widths and speeds creating commonality of spares
- Space saving - narrow / bespoke conveyor sizes
- Fewer motors required for transport conveyor

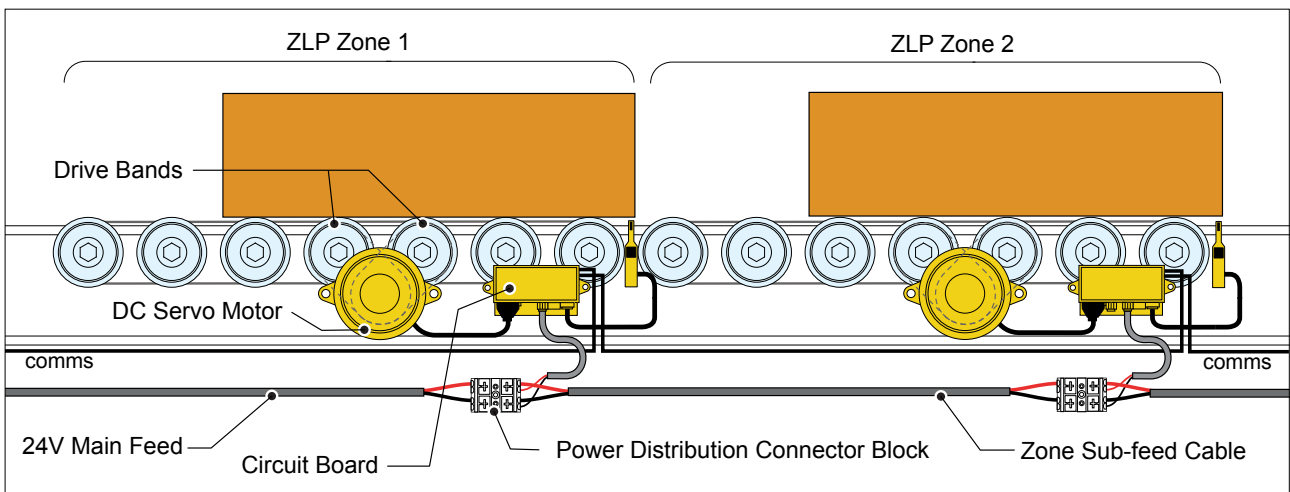

Other products by Conveyor Units include:-

Lineshaft Conveyors
Pallet Conveyors
Belt Conveyors
High Speed Switch Sorters
Belt Under Roller Conveyors
Gravity Conveyors
Stainless Steel Conveyors
Flexible Conveyors
Conveyor Rollers & Spares



Conveyor Units Ltd

Sandy Lane, Titton, Stourport-on-Severn, Worcestershire, DY13 9PT.

Tel: 0044 (0)1299 877541 Fax: 0044 (0)1299 877921

email: sales@conveyor-units.co.uk | www.conveyor-units.co.uk | www.conveyorspares.co.uk