

BELT **CU** MITRE

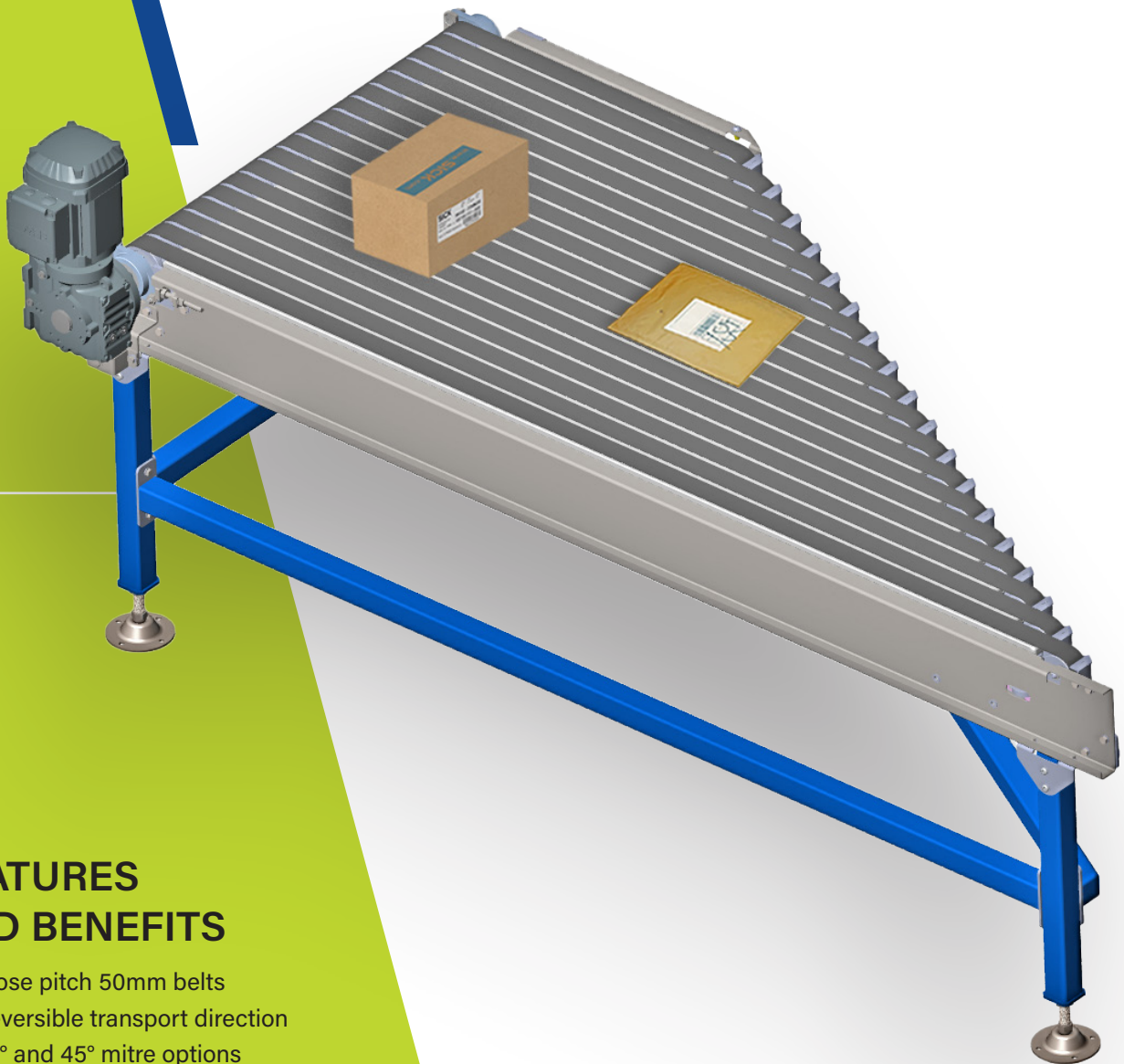

FEATURES AND BENEFITS

- Close pitch 50mm belts
- Reversible transport direction
- 30° and 45° mitre options
- Product weights up to 80 Kg per m

Specifications

A merge/divert module designed for e-commerce and post and parcel distribution requirements.

Multiple strip belts are used to convey small and larger products off or on to conveyor lines.



CONVEYOR UNITS

QUALITY • PERFORMANCE • RELIABILITY

BELT CU MITRE

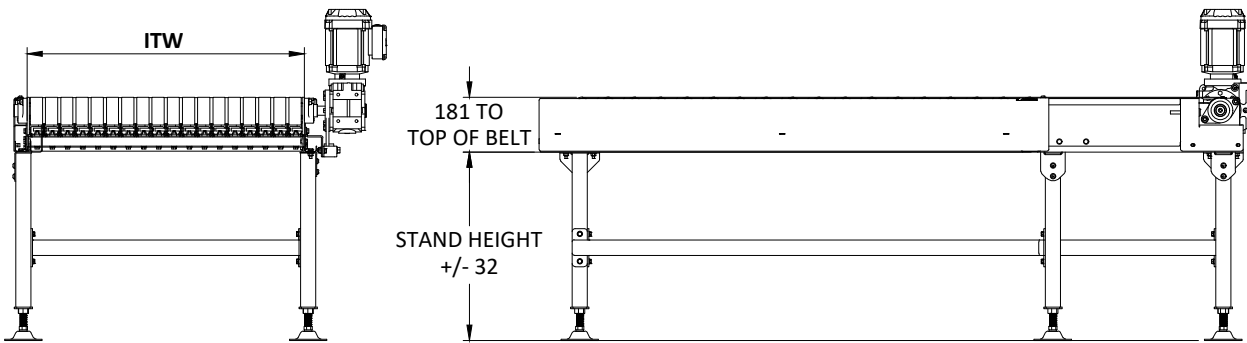

Ref number examples:

BM-0912-030L

LEFT or RIGHT
Angle
Inside Track Width

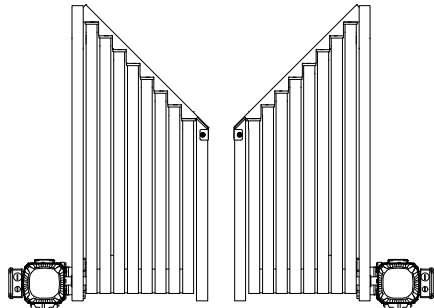

LEFT hand

BM-0412-045L

RIGHT hand

BM-0412-045R

NOTE: Belt Mitres are reversible

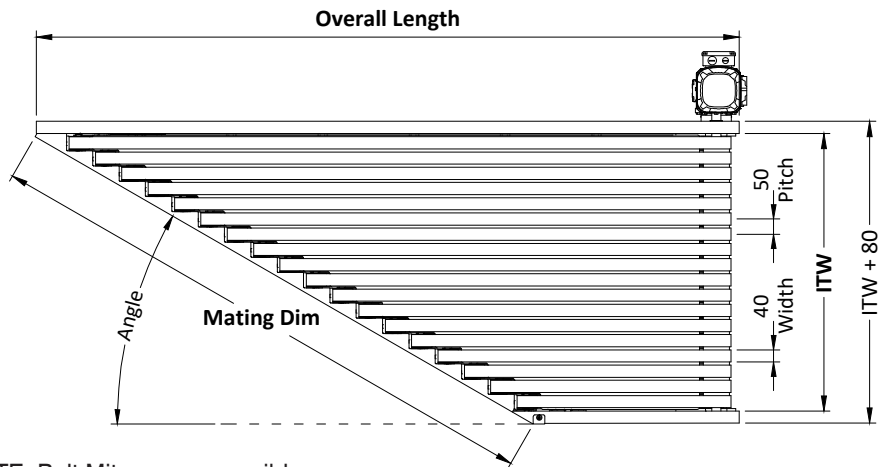

Specifications

Module Height	Up to 1681mm top-of-belt
Stand Height	Up to 1.5m, confirmed at time of order - discuss with sales
Frame Construction	Welded and bolted mild steel construction
Paint Finish	Electrostatically applied powder coating
Drive Technology	SEW hollow shaft, side mounted geared motor 230V/400V
Speeds	10 to 120 m/min
Product Weight	Up to 80 Kg per m
Belts	40mm wide PVC top coated. Tension is pre-set during manufacture. Design facilitates easy replacement and tensioning of individual belts.
Environment	Operating ambient 5° C to 40° C 10-50% RH non-condensing Storage ambient -10° C to 50° C 10-50% RH non-condensing
Noise Level	49 - 69 dB(A) depending on speed (17-76 m/min)

Inside Track Width	30° Mitre		45° Mitre	
	Mating Dim	Overall Length	Mating Dim	Overall Length
912	1890	2309	1337	1570
762	1590	2049	1125	1420
612	1290	1789	913	1270
512	1090	1616	772	1170
462	990	1530	701	1120
412	890	1443	630	1070



Search: Conveyor Units Ltd

+44 (0) 1299 877 541

www.conveyor-units.co.uk

conveyorsales@conveyor-units.co.uk



CONVEYOR UNITS

QUALITY • PERFORMANCE • RELIABILITY